

Assembly Instruction for AKO Pinch Valves Series OV type M (handwheel)



DN 15-50

Step 1a:

Remove the sleeve fixing screw (18) from the lower body half (03).

DN 15-250

Step 1b:

Unscrew the body half screws (16) of the body halves (02-03). Remove the handwheel (14) by loosening the lock nut. Then separate the two body halves (02-03).

Step 2:

Unscrew the sleeve fixing screws (17) and remove the sleeve (04).

Step 3:

Replace the sleeve (04) and mount the sleeve fixing screws (17).

Step 4:

Position the sleeve (04) within the valve body (02-03), lock body half screws (16) and secure the handwheel (14).

PERFORMANCE tESt:

Operate the valve several times and check for easy running closing and opening.

Code	Description	Quantity DN15-50	Quantity DN 65-250
02	Upper body half	1	1
03	Lower body half	1	1
04	Sleeve	1	1
14	Handwheel	1	1
16	Body half screws	4	4
17	Sleeve fixing screws	2	4
18	Lower Sleeve fixing screw	1	0

DN 15 - 250mm

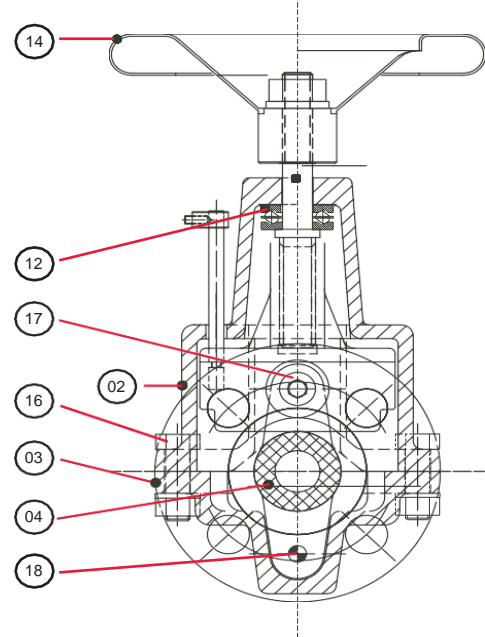

DN 65 - 250mm

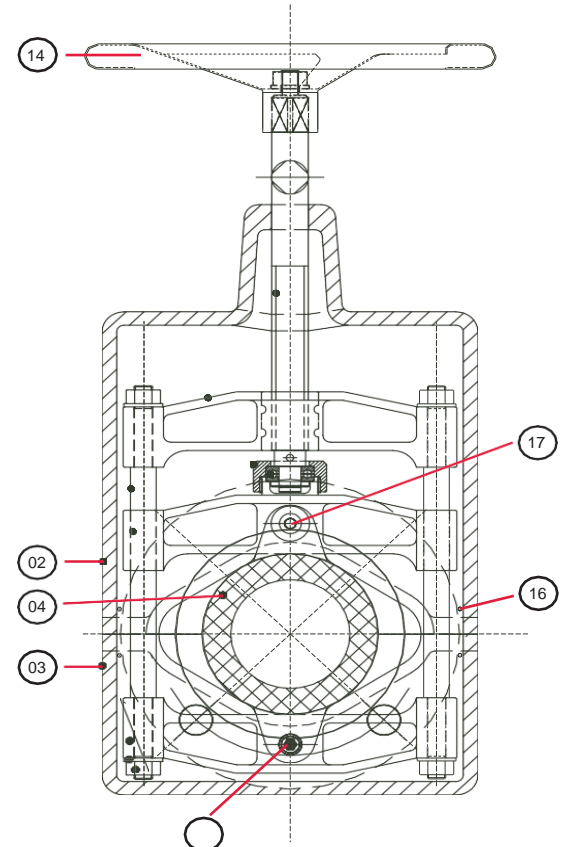

Technical details subject to change without notice.



Basecamp Process Components, LLC

7685-A Corporate Blvd., Plain City, Ohio 43064, USA

T: +1 614-873-8995 • E-mail: info@akopinvalves.com • Web: www.akopinvalves.com